

# VacDry VK3.5: Specifications

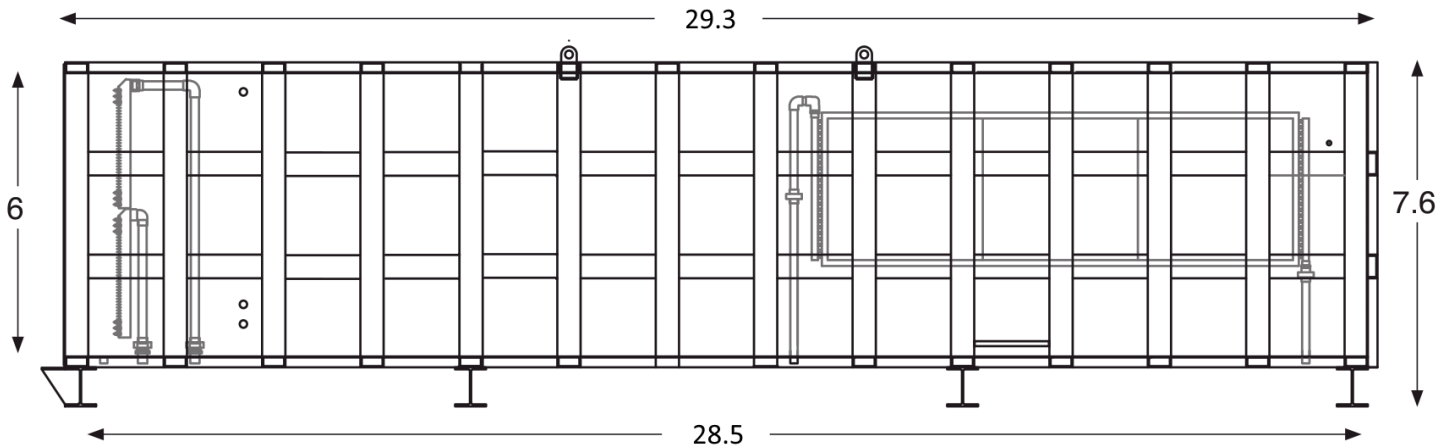

## Projections w/ 8/4 Hard Maple

Layers per Load	26
Max. Boardfeet Capacity	~4500
Boardfeet @ 80% Coverage	~3600
Drying Time	7 Days
Loads per Month	~4
Boardfeet per Month	~14,595
Boardfeet per Year	~175,140

## Requirements w/ 8/4 Hard Maple

Avg Electric Usage per Hour	~6.3 kW
Electric Usage per Load	~1063 kW
Electric Cost @ \$0.11/kWh	~\$117
Avg BTU per Hour	~39,774 BTU
MBTU per Load	~6.6 MBTU
BTU Cost @ \$2.70/gal	~\$121

## Specifications

Kiln Charge Size:	40"W x 66"H x 26'L
Floor Space Required:	~5'W x ~58'L
Shipping Weight:	~28,720 Pounds
Service Entrance:	30A @ 460VAC

